

S hook in reef cringle – Reefing line runs through small block at bottom part of S hook – Nothing is fixed to anything at this area

To use the S hook for a Cunningham, just unhook the S and hook it into the Cunningham cringle in your sail. Take some slack in the reef line and tie off the reef line at the cleat at the

for I used three blocks in addition to the existing setup, and allowed enough line to reach back to the cockpit

Single line reefing as used on Paul David's C22 "Reflections"

Using this method – everything happens in the cockpit.

I do not insert my lower two sail slides into the mast track if I expect to have to reef on the day. I prevent the other slides from dropping out when lowering the sails using a thumbscrew in the track at the mast gate.

To reef, head up and luff the main, then just lower the main halyard to a predetermined position, so that the S hook and reef cringle reach the gooseneck.

At the same time, take in on the reefing line so that the hook pulls down simultaneously on the reef cringle and mainsail clew at the reef point and everything is taut.

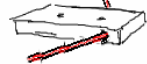

Reflections has a double deck organizer – One of the sheaves is for the main halyard, the other is for the reefing line

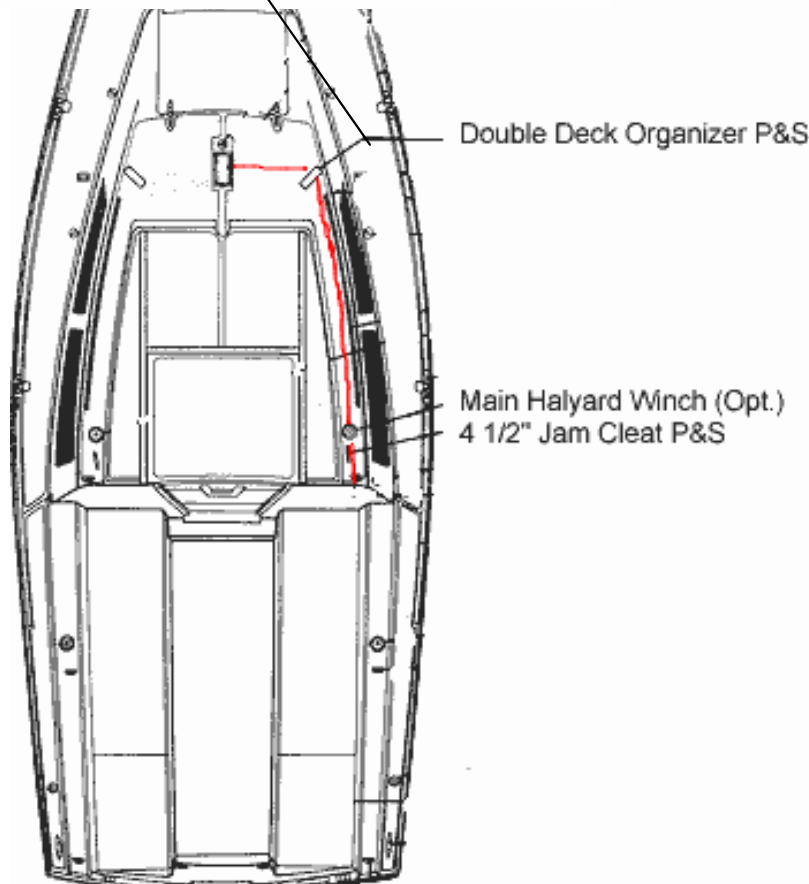

Double Deck Organizer P&S

Main Halyard Winch (Opt.) 4 1/2" Jam Cleat P&S